

# SR5719

## COMPACT ROUGH TERRAIN TELEHANDLER



- Full-time 4-wheel drive
- Fully enclosed cab
- Power assisted steering
- Proportional joystick
- Simple to operate & maintain

 **snorkel**<sup>™</sup>  
[www.snorkellifts.com](http://www.snorkellifts.com)

# COMPACT ROUGH TERRAIN TELEHANDLER

# SR5719

## CAPABILITIES SR5719

Max. lift capacity	5,732 lbs
Max. lift height (A)	19 ft
Max. forward reach	10 ft 4 in

## DIMENSIONS

Overall width (B)	6 ft 2 in
Stowed height (C)	6 ft 4 in
Length to fork face (D)*	13 ft 9 in
Wheelbase	8 ft 3 in
Ground clearance	9 in

## PERFORMANCE

Max. drive speed	16.7 mph
Raise/lower time	6.9/5 sec
Hydraulic flow (per minute)	18.5 gal
Hydraulic pressure	3,336 psi
Hydraulic oil capacity	18.5 gal
Fuel capacity	21 gal
Outside turning radius	10 ft 8 in
Tires	12 x 16.5

## POWER

Power source	Yanmar 70.3hp - Tier 4 Final diesel
--------------	-------------------------------------

## WEIGHT

Weight	10,360 lbs
--------	------------

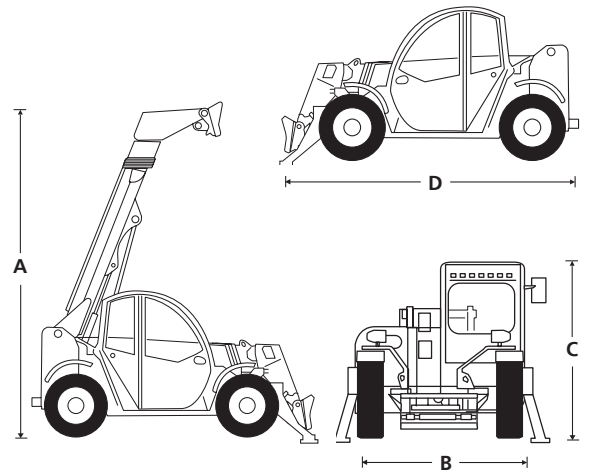

## STANDARD FEATURES

- Easy access to components for servicing
- Full-time 4-wheel drive
- 4-wheel steer
- Selectable front, crab & coordinated steering modes
- Auxiliary hydraulic circuit on the boom
- Variable speed hydrostatic drive
- Proportional joystick
- Illuminated gauge and switch panels
- Color LCD display with machine & engine diagnostics
- Block heater
- Constant flow
- Adjustable suspension seat
- LED road lights (4)
- LED work lights on boom (2)
- 2 year parts & labor, 5 year structural warranty
- ANSI compliant

## OPTIONS

- Special paint colors
- Multiple options for carriages, tires and fork tines
- Cold weather synthetic oil
- Swivel hook
- Hydraulic tank heater
- Universal skidsteer attachments
- Snorkel OnSite™ telematics

## LOAD CHART

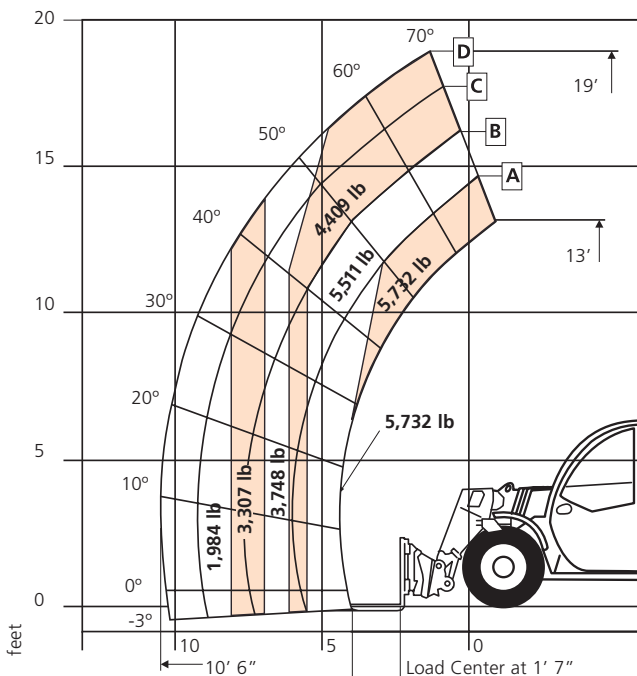

**snorkel** [www.snorkellifts.com](http://www.snorkellifts.com)

P.O. Box 1160  
 St. Joseph, MO 64502-1160, USA  
 Tel: 1 (785) 989-3000  
 Toll-free: 1 (800) 255-0317  
 Fax: 1 (785) 989-3070  
 Email: sales.usa@snorkellifts.com